



Hazardous Area Classification

Explosive Gas Atmospheres

PCIC Energy Europe Conference Tutorial
Presentation, June 2, 2026

Allan Bozek, MBA, P.Eng. EngWorks Inc., Calgary, CANADA

Tutorial Agenda



1. *Overview of the basic concepts of Hazardous Area Classification*
2. *Discuss the various Codes, Standards and Recommended Practices for classification design with an emphasis on IEC 60079-10-1*
3. *Provide guidelines on how to properly document your analysis*

Definition of a Hazardous Area

An area in which an explosive gas atmosphere is or may be expected to be present, in quantities such as to require special precautions for the construction, installation and use of equipment

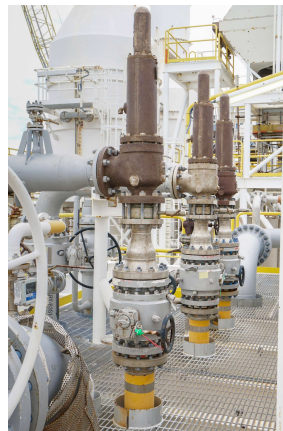

IEC 60079-10-1

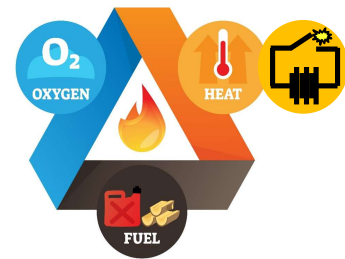

Primary Objectives of a Hazardous Area Classification

- Primarily used for establishing the type of electrical equipment and wiring methods that can be used within a hazardous location



PCIC energy

4

Secondary Objectives of a Hazardous Area Classification

- ATEX Directive



– Essential Health and Safety requirements with respect to:

- Potential ignition sources from equipment in hazardous locations
 - Applies to non-electrical equipment
- Local Occupational Health & Safety Requirements
 - Hazardous area classification is now being used as a basis for implementation of the OH&S codes and standards
 - The hazardous area classification design is being used as a tool for performing the hazard risk assessment
 - Regulates the work activities performed within a classified location

PCIC energy

5

Scope of a Hazardous Area Classification

- Fugitive emissions in plant operations are normal and expected
 - An area classification is valid under “Normal” and defined “abnormal” operating conditions
 - An abnormal condition is where a leak is detected but the process continues until such time as a repair can be made
- Catastrophic releases where large amounts of flammable material are released due to an equipment containment failure are not considered

Industrial Fugitive Emissions Sources

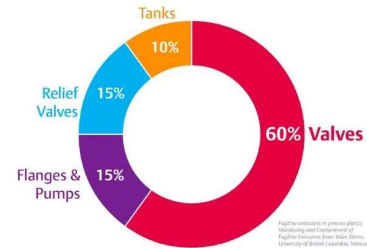

Application

- Applies to the “normal” operation of facilities
 - “normal” is when equipment operating within its normal parameters
 - Does not apply to “rare malfunctions” or “catastrophic failures”
 - Does not apply to activities such as commissioning or turnaround activities



Who needs this information?

- **Engineers**

- Equipment selection
- Equipment placement
- Ventilation design



PCIC energy



- **Equipment Suppliers**

- Component selection
- Certification requirements

8

Who needs this information?

- **Installers**

- Assembly component selection
- Wiring methods



PCIC energy

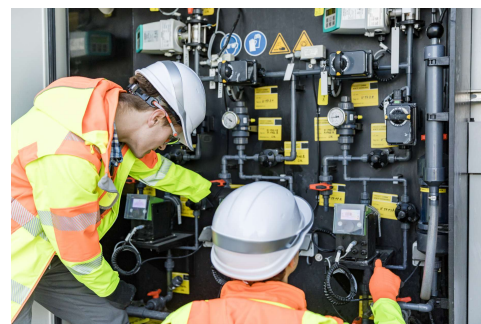

- **Inspectors**

- QA/QC
- Code compliance

9

Who needs this information?

• Operations

- Safe Work Procedures
- Hot Work permitting

HOT WORK PERMIT

DATE ISSUED: _____ DATE EXPIRES: _____

LOCATION OF WORK: _____ PERMIT # _____

ISSUING AUTHORITY: _____

APPROVED BY: _____

LOCATION: _____

POTENTIAL HAZARDS: _____

SAFETY EQUIPMENT: _____

THIS PERMIT IS GOOD FOR 1 DAY ONLY



What do they need to know?

1. Zone or Division classification
2. Extent of the classified area
3. Group Classification of the flammable materials
4. Auto-ignition temperature of the flammable materials

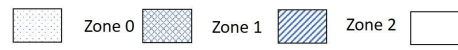
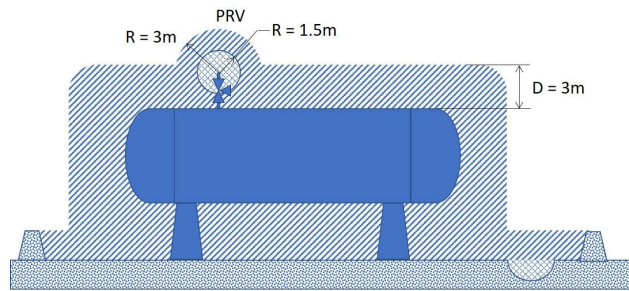
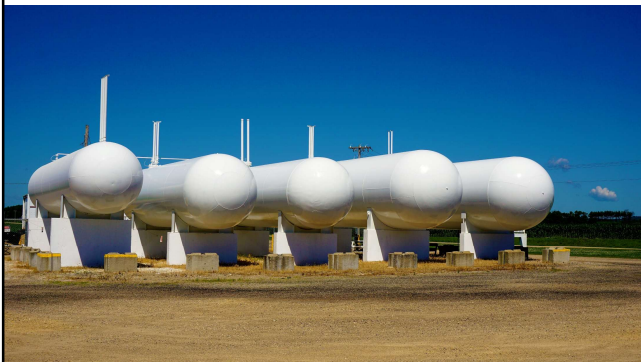

Group IIA, AIT = 200°C (T3)

Zone vs Division Classification

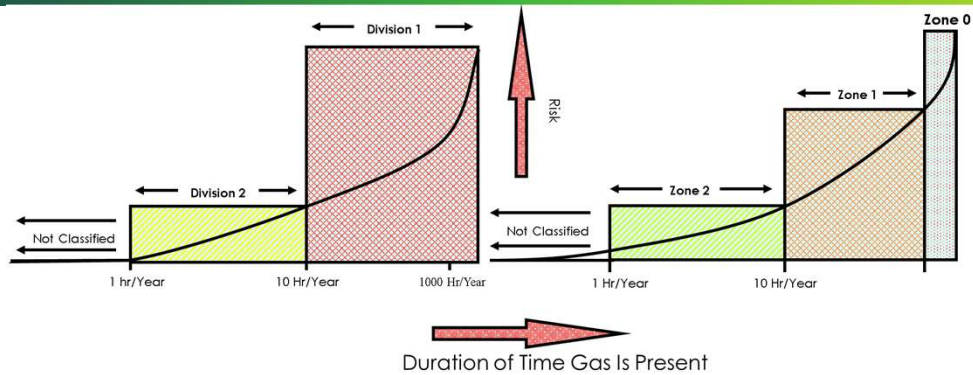

Class	Definition of the Hazard
Zone or Division	Probability that a hazard may exist
Group	Characteristics of the Hazardous Materials
AIT	Auto-ignition temperature of the Hazardous Materials

Group Classification

Group	Material	MESG (mm)	MIE (mJ)
IIA	Methane	1.12	0.28
	Propane	0.97	0.28
	Butane	1.07	0.25
	Heptane	0.91	0.24
	Pentane	0.93	0.28
IIB	H2S	0.89	0.068
	Ethylene	0.65	0.070
IIC	Hydrogen	0.28	0.019
	Acetylene	0.25	0.017

MESG – Maximum Experimental Safe Gap
MIE – Minimum Ignition Energy

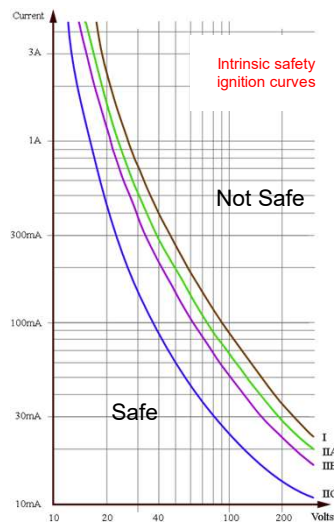
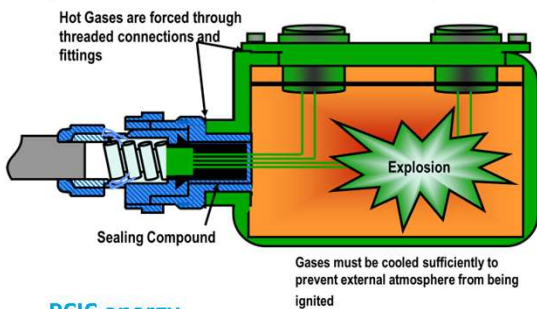

Division	Zone
A	IIC
B	IIB + H ₂
C	IIB
D	IIA

Auto-Ignition Temperature (AIT)

IEC 60079-0

“Lowest temperature (of a surface) at which under specified test conditions an ignition of a flammable gas or vapour in mixture with air or air-inert gas occurs”

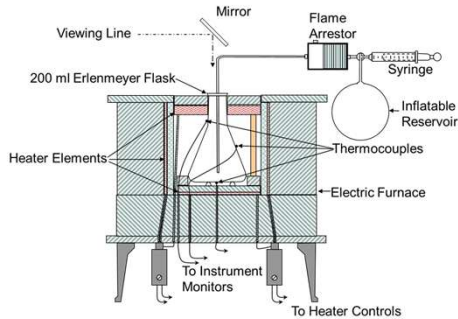

IEC Test Apparatus

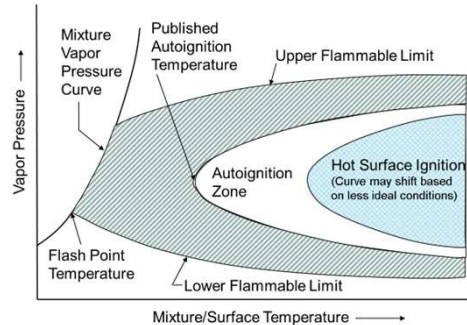

Temperature Code Application

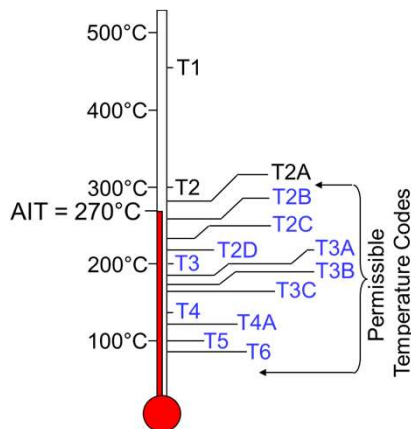

- Maximum surface operating temperature of the device cannot exceed the AIT defined for the area

T1 - 450°C	T3A - 180°C
T2 - 300°C	T3B - 165°C
T2A - 280°C	T3C - 160°C
T2B - 260°C	T4 - 135°C
T2C - 230°C	T4A - 120°C
T2D - 215°C	T5 - 100°C
T3 - 200°C	T6 - 85°C

When do they need this information?

- In the early stages of a design project before any major equipment is purchased!
- Prior to construction to select the appropriate wiring methods

Project Scheduling Management

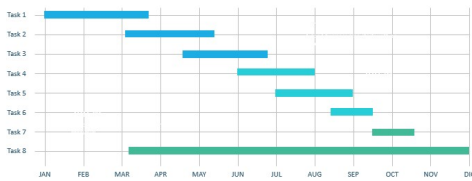

PCIC energy



16

Who is responsible for providing it?

- The Owner
 - Usually performed by an engineering consultant contracted by the Owner
- Considered to be an important safety document that must be maintained over the life of the facility
- Must be provided upon request by safety inspection authorities



PCIC energy

17

Hazardous Area Classification (HAC) Risk Assessment

- **Not an Electrical Engineering design function!**

- An Electrical Engineer is an end User who uses the information to select electrical equipment appropriate for the classification

- Requires input from:

- Process Engineering

- Properties of the flammable materials
 - Pressures and temperature of the process

- Mechanical

- Identify sources of release
 - Enclosed area ventilation design

- Operations

- Hot work permit and housekeeping procedures



HAC Design Issues

- Based on the likelihood of a flammable mixture being present under “normal” and defined “abnormal” conditions

- Must be carried out *before* the choice of equipment and wiring methods are made

- Source of ignition is not a criteria for classification
 - Often treated as an afterthought after a facility is constructed

- HAC Documents issued and used with incomplete information

- Undocumented designs

- No way of maintaining the classification design over the life of the facility

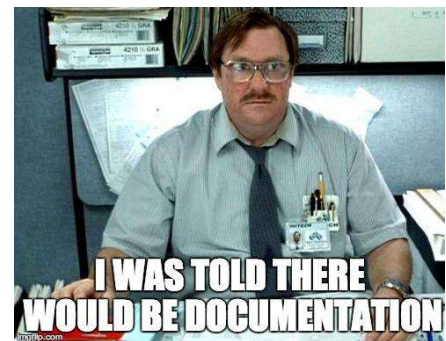

Common issues found in many HAC designs

- No group classification or Auto-ignition temperature and/or T-Code indicated on the drawings
 - Errors in the group classification of materials
 - Errors in determining the appropriate auto-ignition temperature and equipment temperature code
- Classification of locations where no flammable materials are present
- Over classification of areas relative to the risk
- Inconsistent application of classifications surrounding similar equipment items
- Unsupported classification of enclosed areas where adequate ventilation is required

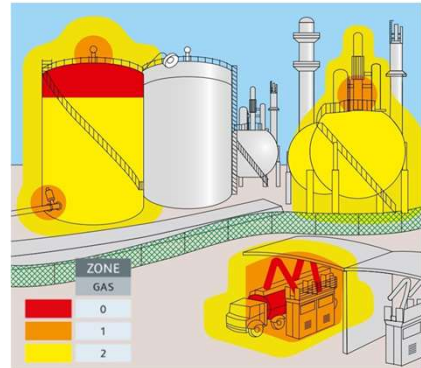

Competence of Personnel

“The hazardous area classification should be carried out by persons who understand the nature of flammable substances, gas dispersion and ventilation and are familiar with the process aspects for the plant under consideration. It may be beneficial for other engineering disciplines, e.g. electrical and mechanical engineers, and personnel with specific responsibility for safety to be part of and have an input to the hazardous area classification process. The competency of the person shall be relevant to the nature of the plant and methodology used for carrying out the hazardous area classification. Appropriate continuing education or training should be undertaken by personnel on a regular basis where required”

IEC 60079-10-1



Competence

- IEC Certificate of Personnel Competence
- Verifies competence of an individual to perform defined tasks related to explosion protection
- Proctored exam performed by IECEx approved certification agency
- Successful candidates are provided with a certificate and are listed in IECEx COPC database

PCIC energy

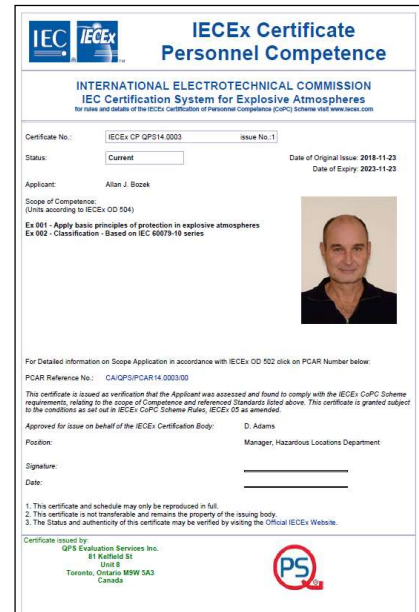

IECEx Certificate of Personnel Competence

INTERNATIONAL ELECTROTECHNICAL COMMISSION
IEC Certification System for Explosive Atmospheres
For news and details of the IECEx Certification of Personnel Competence (COPC) scheme visit www.iecex.com

Certificate No.: IECEx CP QPS14 0003 Issue No.: 1
Status: Current Date of Original Issue: 2018-11-23
Date of Expiry: 2023-11-23
Applicant: Alan J. Buzek

Scope of Competence:
(Units according to IECEx OD 004)
Ex 001 - Apply basic principles of protection in explosive atmospheres
Ex 002 - Classification - Based on IEC 60079-10 series

For Detailed information on Scope Application in accordance with IECEx OD 002 click on PCAR Number below:
PCAR Reference No.: CA/QPS/PCAR/14/0003/00

This certificate is issued as verification that the Applicant was assessed and found to comply with the IECEx COPC Scheme requirements, relating to the scope of Competence and referenced Standards listed above. This certificate is granted subject to the conditions as set out in IECEx COPC Scheme Rules, IECEx 03 as amended.

Approved for issue on behalf of the IECEx Certification Body: D. Adams
Position: Manager, Hazardous Locations Department

Signature: _____
Date: _____

1. This certificate and schedule may only be reproduced in full.
2. This certificate is not transferable and remains the property of the issuing body.
3. The Status and authenticity of this certificate may be verified by visiting the Official IECEx Website.

Certificate issued by:
QPS Evaluation Services Inc.
81 Keefe St
Unit 8
Toronto, Ontario M9W 5A3
Canada



PCiC
energy

Method of
Classification

Design Objectives: IEC 60079-10-1

- *“Zone 0 or zone 1 areas should be minimised in number and extent by design or suitable operating procedures. In other words, plants and installations should be mainly zone 2 or non-hazardous”*
 - Implies that flammable releases should not be intentional
 - Where a process is operating abnormally, the amount of flammable material released should be minimized

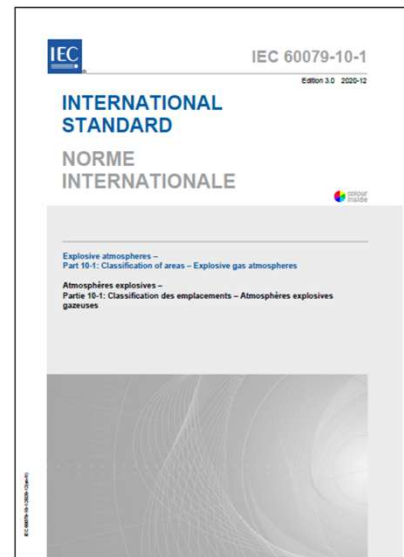

Area Classification Methodologies

- Simplified Methods
 - Use of diagrams to convey zones and extents
- Source of Release Methods
 - Based on calculations to determine zone classification and extent
- Operating experience
 - Facilities are classified based on operating experience with same or similar installations
- Combination of Methods

Simplified Methods

- Used where it is not practicable to make a proper assessments from individual sources of release
 - Process information is of poor quality
 - Plant documentation is incomplete
 - FEED stage of a project
- Involves applying standard diagrams depicting the classification surrounding typical sources of release Diagrams may be based on:
 - Industry publications
 - Operating experience.

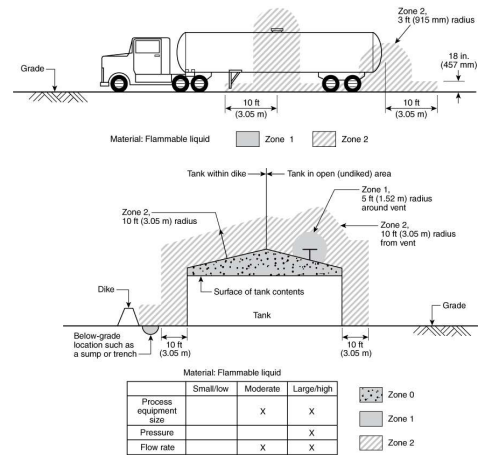

Use of Industry Codes and National Standards (IEC 60079-10-1)

- *“Industry codes and national standards may be used where they provide guidance or examples appropriate to the application and comply with the general principles of this standard”*
- Annex K of IEC-60097-10-1 provides a list of “acceptable standards”
 - API RP 505, NFPA 497, EI 15
 - *“The diagrams provided in the publications must be applied with “Good Engineering Judgement” taking in account the basis for the diagram in the publication and the actual situation to be classified”*

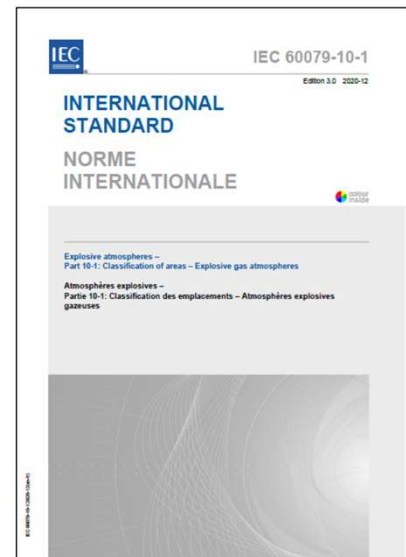

API RP 500 & RP 505

- API 500 refers to Division Classified areas as defined in Article 500 of the NEC
- API 505 refers to Zone Classified areas as defined in Article 505 of the NEC
 - Prescriptive in nature
 - If this is the situation – this is how you should classify the area
 - Does not attempt to describe the properties of flammable materials
 - References NFPA 497 for flammable fluid data

Note that the API documents reference NEC requirements. In some cases, the API Recommended Practices may not be compliant with other national codes and standards



API RP 505 Figure 20

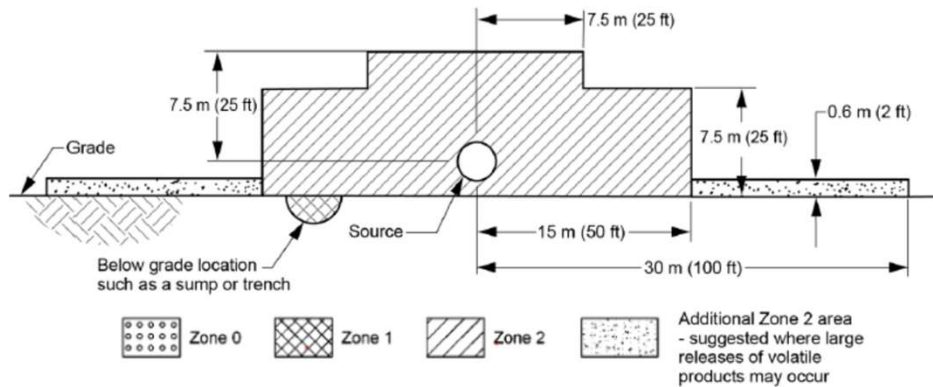

[1] Distances given are for typical refinery installations; they shall be used with judgment, with consideration given to all factors discussed in the text. In some instances, greater or lesser distances may be justified.

Figure 20—Adequately Ventilated Process Location with Heavier-than-air Gas or Vapor Source Located Near Grade (See 9.2.1.1)

NFPA 497

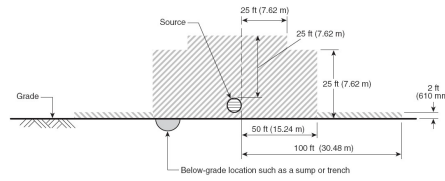
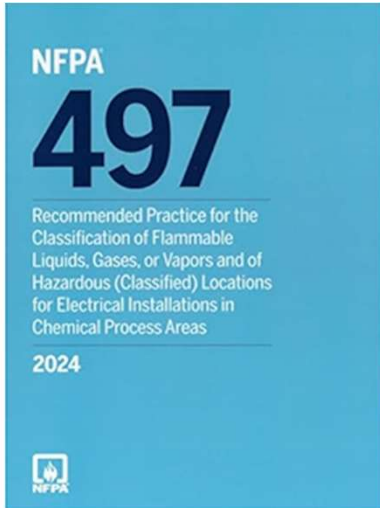

Material: Flammable liquid

Process equipment size	Small/low	Moderate	Large/high
Pressure		X	X
Flow rate		X	X

Zone 1
 Zone 2
 Additional Zone 2 location. Use extra precaution where large release of volatile products may occur.

FIGURE 5.10.1(g) Leakage Located Outdoors, at Grade. The material being handled is a flammable liquid.

Table 5.7.4 Relative Magnitudes of Process Equipment and Piping that Handles Combustible Materials

Process Equipment	Units	Small (Low)	Moderate	Large (High)
Size	gal	<3000	5000-25,000	>25,000
Pressure	psi	<100	100-500	>500
Flow rate	gpm	<100	100-500	>500

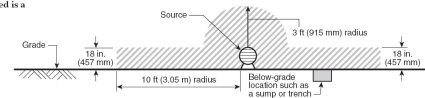

Material: Flammable liquid

Process equipment size	Small/low	Moderate	Large/high
Pressure	X	X	
Flow rate	X	X	

Zone 1
 Zone 2

FIGURE 5.10.1(a) Leakage Located Outdoors, at Grade. The material being handled is a flammable liquid.

EI 15 Model Code of Safe Practice

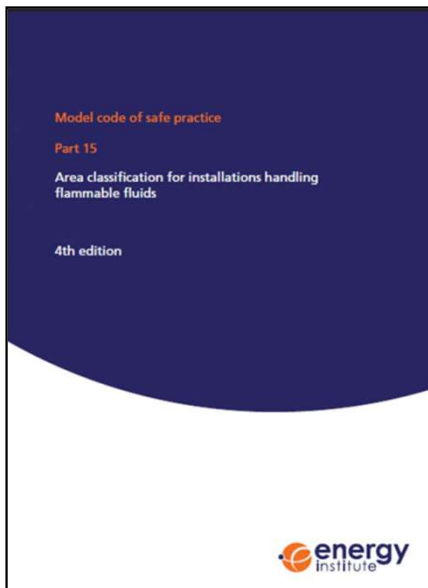

- Incorporates three different approaches to area classification
 - Introduces the concept of a risk-based approach to area classification
 - First code to use dispersion modeling as a basis for defining the extent of classified areas

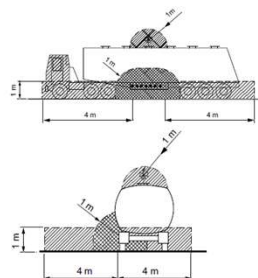

Note: Ullage space in the road tanker should be classified as Zone 0.

Figure D16: Typical hazardous area zone classification of a road tanker during unloading.

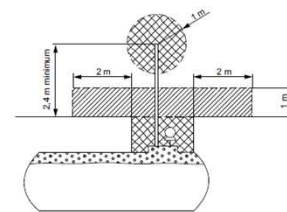

Figure D29: Typical hazardous area zone classification for an oil/water separator

Source of Release Methods: IEC 60079-10-1

1. Identify potential sources of release
2. Determine the release rate and grade of release for each source based on likely frequency and duration of release
3. Assess ventilation effectiveness;
4. Determine the appropriate zone based on grade of release and ventilation effectiveness;
5. Determine the appropriate extent of the zone

Choked Gas Release

$$W_g = C_d S p \sqrt{\gamma \frac{M}{Z R T} \left(\frac{2}{\gamma + 1} \right)^{(\gamma + 1)/(\gamma - 1)}} \quad (\text{kg/s})$$

Table D.1 – Zones for grade of release and effectiveness of ventilation

Grade of release	Effectiveness of Ventilation						
	High Dilution			Medium Dilution			Low Dilution
	Availability of ventilation						
	Good	Fair	Poor	Good	Fair	Poor	Good, fair or poor
Continuous	Non-hazardous (Zone 0 NE)	Zone 2 (Zone 0 NE)	Zone 1 (Zone 0 NE)	Zone 0	Zone 0	Zone 0	Zone 0
Primary	Non-hazardous (Zone 1 NE)	Zone 2 (Zone 1 NE)	Zone 2 (Zone 1 NE)	Zone 1	Zone 1	Zone 1	Zone 1 or Zone 0
Secondary	Non-hazardous (Zone 2 NE)	Non-hazardous (Zone 2 NE)	Zone 2	Zone 2	Zone 2	Zone 2	Zone 1 and even Zone 0

Figure D.1 – Chart for estimating hazardous area distances

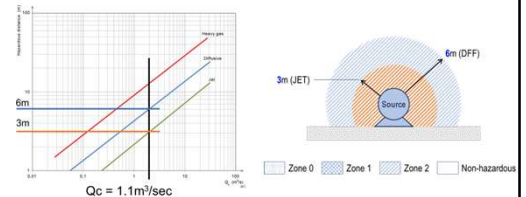

PCIC energy

32

Operating Experience

“When classifying areas consideration should be also given to a careful evaluation of the same or similar installations...”

... Where documented evidence indicates that a particular plant design and operations are sound this may be used to support the classification chosen...

...furthermore, it is conceivable that an area could be reclassified based on new evidence”



IEC 60079-10-1
NFPA 497

PCIC energy

33

Combination of Methods

- Different methods may be appropriate for classification of a facility at various stages of its design development
 - Preliminary (FEED) design: Simplified Methods
 - Detailed design: Point Source Methods
- Simplified methods can be applied to a group of similar equipment items (e.g. sections of piping with flanges, such as pipe racks) while applying a more detailed assessment to the more significant potential sources of release (Process buildings, gas compressors, pumps)



Classification using
IEC 60079-10-1

Design Objectives

- “Zone 0 or Zone 1 areas should be minimized in number and extent by design or suitable operating procedures.”
- “In other words, plants and installations should be mainly zone 2 or non-hazardous”

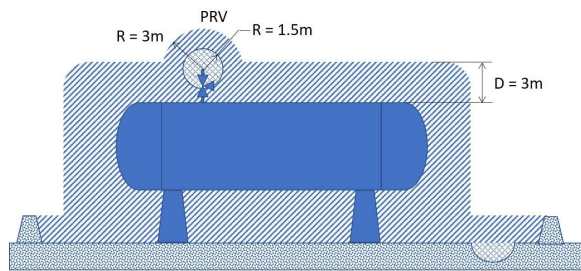

PCIC energy

Group IIA, AIT = 200°C (T3)

1. Zone
2. Extent of the zone
3. Material Characteristics
 - Group classification
 - Auto-ignition temperature (AIT)

36

When should it be done?

- Start when initial P&ID and plot plans are available
- Preliminary design
 - *Equipment specifications for long lead items*
- Detailed design
 - *Optimize classification extents*
 - *Define ventilation requirements*

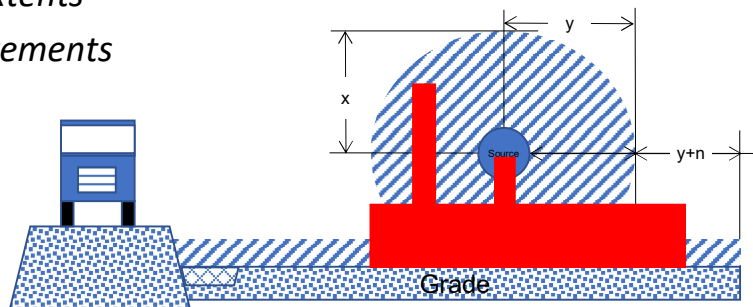

PCIC energy

37

Source of Release Method: IEC 60079-10-1

Annex F Schematic approach to classification of hazardous areas

1. Identify potential sources of release
2. Determine the grade of release and the release rate
3. Assess ventilation effectiveness
4. Determine the zone
5. Determine the extent

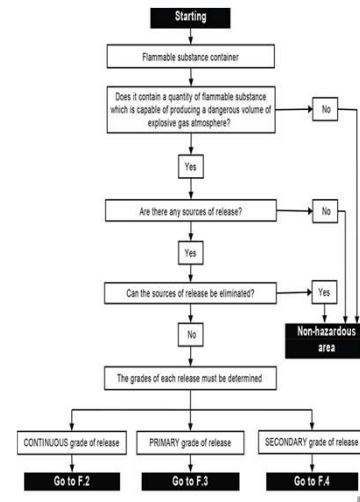

PCIC energy

38

Sources of Release

Pressure Relief Valves (PRVs) with moving elements

Parts moving at high speed

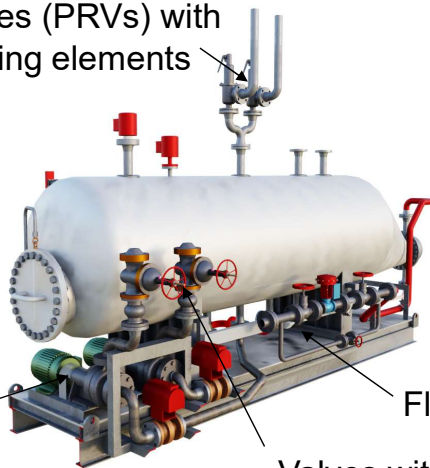

Flanges and Piping Connections

Valves with sealing elements

- Sealing Elements on fixed parts
- Sealing elements on moving parts
- Releases resulting from the process being open to atmosphere
- All welded piping is not considered a source of release

PCIC energy

39

Grade of Release

Grade	Frequency of Release	Duration of Release
Continuous	Frequent	Long
Primary	Periodic	Long
Secondary	Infrequent	Short



Continuous



PCIC energy



Secondary

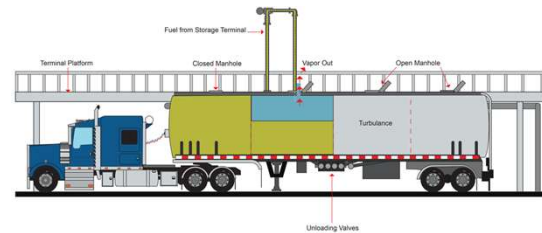

Primary

Determine the Rate of Release

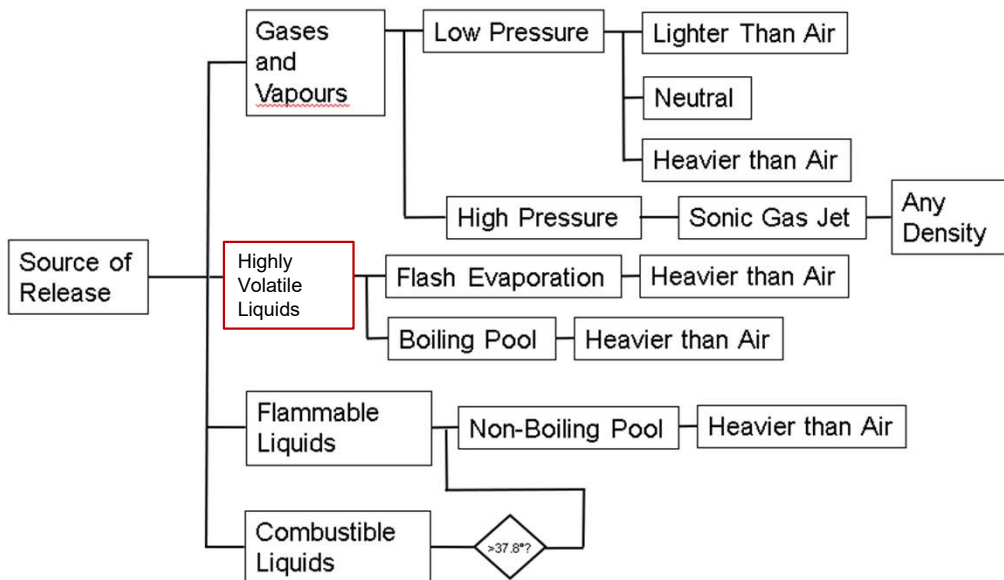

Low Pressure Gas Release Behavior

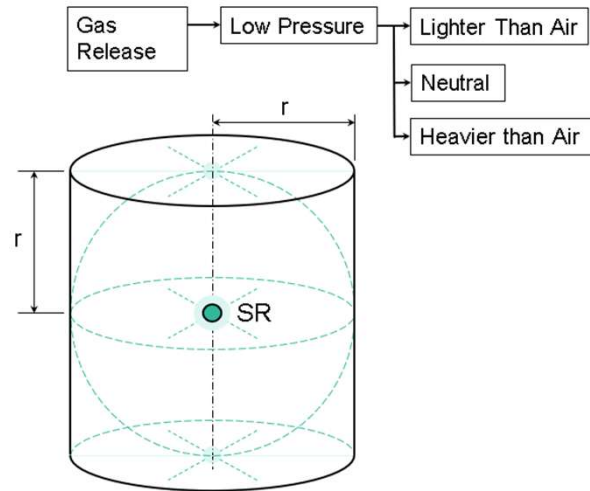

PCIC energy

42

High Pressure Gas Release Behavior

43

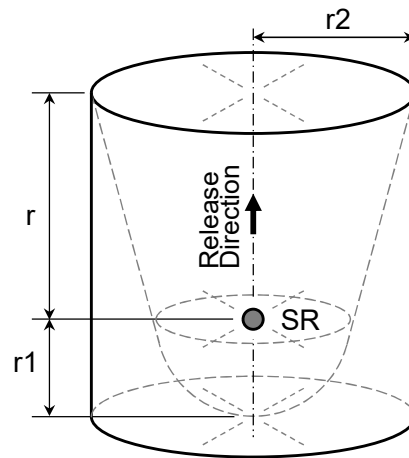
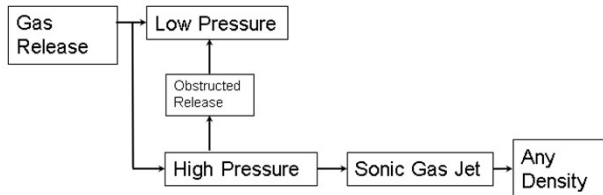

PCIC energy

43

Calculating Gas Release Rates

Subsonic Release

$$W_g = C_d S p \sqrt{\frac{M}{ZRT} \frac{2\gamma}{\gamma-1} \left[1 - \left(\frac{p_a}{p} \right)^{(\gamma-1)/\gamma} \right]} \left(\frac{p_a}{p} \right)^{1/\gamma} \text{ (kg/s)}$$

Sonic Release

$$W_g = C_d S p \sqrt{\gamma \frac{M}{ZRT} \left(\frac{2}{\gamma+1} \right)^{(\gamma+1)/(\gamma-1)}} \text{ (kg/s)}$$

- W_g = mass release rate of gas (kg/s)
- Source of release properties
 - C_d = discharge coefficient of the release opening
 - S = cross section of the hole opening (m²)
 - p_a = atmospheric pressure (101 325 Pa)
 - p = pressure inside the container (Pa)
- Material Properties
 - M = molar mass of gas or vapour (kg/kmole)
 - Z = compressibility factor (dimensionless)
 - R = Universal gas constant (8314 J/kmole K)
 - T = Absolute temperature of the gas (° K)
 - γ = polytropic index of adiabatic expansion (Ratio of Specific Heats) (dimensionless)

Determining the Hole Size

Subsonic Release

$$W_g = C_d S p \sqrt{\frac{M}{ZRT} \frac{2\gamma}{\gamma-1} \left[1 - \left(\frac{p_a}{p} \right)^{(\gamma-1)/\gamma} \right]} \left(\frac{p_a}{p} \right)^{1/\gamma} \text{ (kg/s)}$$

Sonic Release

$$W_g = C_d S p \sqrt{\gamma \frac{M}{ZRT} \left(\frac{2}{\gamma+1} \right)^{(\gamma+1)/(\gamma-1)}} \text{ (kg/s)}$$

Table B.1 – Suggested hole cross sections for secondary grade of releases

Type of item	Item	Leak Considerations		
		Typical values for the conditions at which the release opening will not expand	Typical values for the conditions at which the release opening may expand, e.g. erosion	Typical values for the conditions at which the release opening may expand up to a severe failure, e.g. blow out
		S (mm ²)	S (mm ²)	S (mm ²)
Sealing elements on fixed parts	Flanges with compressed fibre gasket or similar	≥ 0,025 up to 0,25	> 0,25 up to 2,5	(sector between two bolts) (gasket thickness) usually ≥ 1 mm
	Flanges with spiral wound gasket or similar	0,025	0,25	(sector between two bolts) (gasket thickness) usually ≥ 0,5 mm
	Ring type joint connections	0,1	0,25	0,5
Sealing elements on moving parts at low speed	Small bore connections up to 50 mm ^a	≥ 0,025 up to 0,1	> 0,1 up to 0,25	1,0
	Valve stem packings	0,25	2,5	To be defined according to Equipment Manufacturer's Data but not less than 2,5 mm ^b
Sealing elements on moving parts at high speed	Pressure relief valves ^c	0,1 × (orifice section)	NA	NA
	Pumps and compressors ^d	NA	≥ 1 up to 5	To be defined according to Equipment Manufacturer's Data and/or Process Unit Configuration but not less than 5 mm ^e

^a Hole cross sections suggested for ring joints, threaded connections, compression joints (e.g. metallic compression fittings) and rapid joints on small bore piping.

^b This item does not refer to full opening of the valve but to various leaks due to malfunction of the valve components. Specific applications could require a hole cross section bigger than suggested.

^c Reciprocating Compressors – The frame of compressor and the cylinders are usually not items that leak but the piston rod packings and various pipe connections in the process system.

^d Equipment Manufacturer's Data – Cooperation with equipment's manufacturer is required to assess the effects in case of an expected failure (e.g. the availability of a drawing with details relevant to sealing devices).

^e Process Unit Configuration – In certain circumstances (e.g. a preliminary study), an operational analysis to define the maximum accepted release rate of flammable substance may compensate lack of equipment manufacturer's data.

NOTE Other typical values or guidance on erosion and failure conditions may also be found in national or industry codes relevant to specific applications.

Highly Volatile Liquids (HVLs) (Liquified by Pressure or Refrigeration)

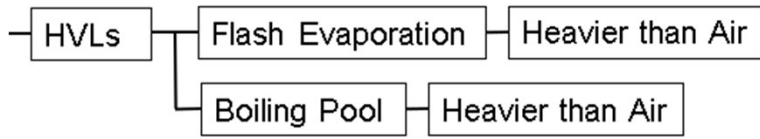

$$W = C_d S \sqrt{2 \rho \Delta p}$$

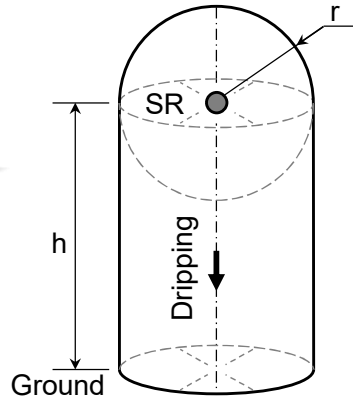

- W_g = mass release rate of liquid (kg/s)
- Source of release properties
 - C_d = discharge coefficient of the release opening
 - S = cross section of the hole opening (m²)
 - Δp = pressure difference across the leak (Pa)
- Material Properties
 - ρ = liquid density (kg/m³)

PCIC energy

46

Liquid Releases

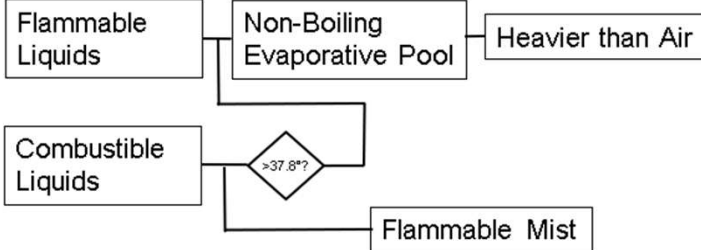

PCIC energy

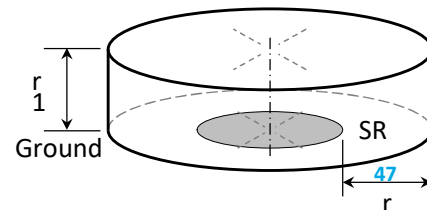
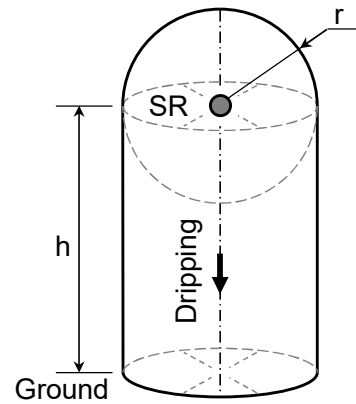

Liquid Releases

$$W = C_d S \sqrt{2\rho\Delta p} \text{ (kg/s)}$$

$$W_e = \frac{18,3 \times 10^{-3} u_w^{0,78} A_p p_v M^{0,667}}{R \times T} \text{ (kg/s)}$$

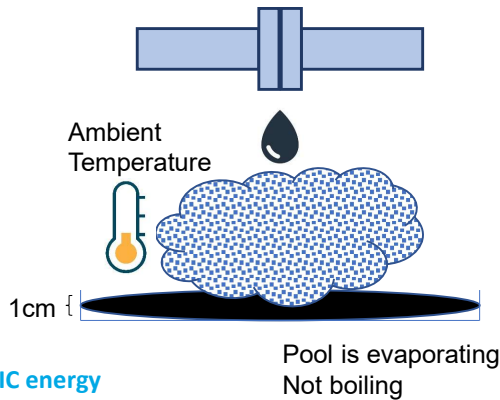

PCIC energy

- W_g = release rate of liquid (kg/s)
- W_e = Evaporation rate of a liquid (kg/s)
- Source of release properties
 - C_d = discharge coefficient of the release opening
 - S = cross section of the hole opening (m²)
 - Δp = pressure difference across opening (Pa)
 - A_p = Pool Surface Area
- Material Properties
 - M = molar mass of gas or vapour (kg/kmole)
 - R = Universal gas constant (8314 J/kmole K)
 - T = Absolute temperature of the gas (° K)
 - p_v = Vapour pressure of liquid at temperature

48

Assess Ventilation Effectiveness

Purpose of Ventilation

1. Dilute and disperse a flammable release
2. Ensure that a release does not persist

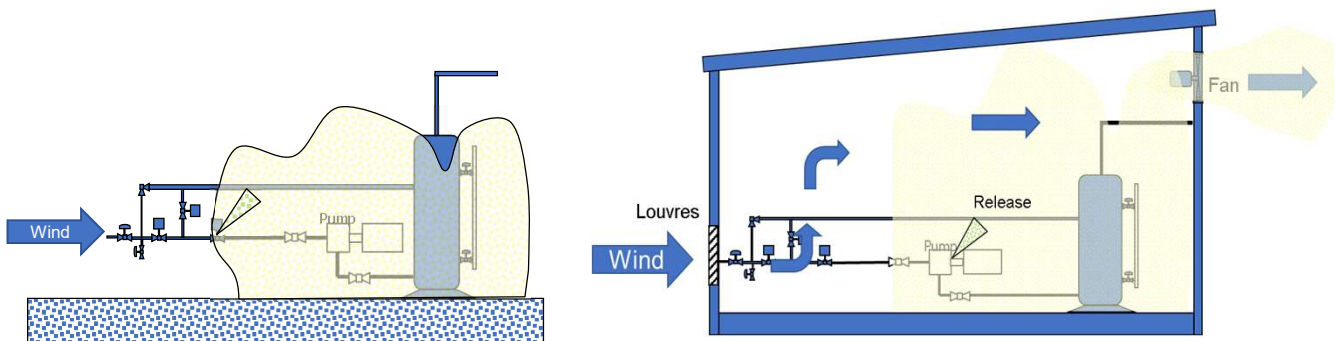

PCIC energy

49

Effectiveness of Ventilation

Effectiveness depends on:

- Degree of dilution
- Availability
- Ventilation system design

Table D.1 – Zones for grade of release and effectiveness of ventilation

Grade of release	Effectiveness of Ventilation						
	High Dilution			Medium Dilution			Low Dilution
	Availability of ventilation						
	Good	Fair	Poor	Good	Fair	Poor	Good, fair or poor
Continuous	Non-hazardous (Zone 0 NE)	Zone 2 (Zone 0 NE)	Zone 1 (Zone 0 NE)	Zone 0	Zone 0 + Zone 2	Zone 0 + Zone 1	Zone 0
Primary	Non-hazardous (Zone 1 NE)	Zone 2 (Zone 1 NE)	Zone 2 (Zone 1 NE)	Zone 1	Zone 1 + Zone 2	Zone 1 + Zone 2	Zone 1 or zone 0
Secondary	Non-hazardous (Zone 2 NE)	Non-hazardous (Zone 2 NE)	Zone 2	Zone 2	Zone 2	Zone 2	Zone 1 and even Zone 0

Dilution – Assessment

Q_C = Volume Release Characteristic

$$Q_C = \frac{W_g}{\rho_g \times LFL} (m^3/sec)$$

W_g – Mass release rate (kg/sec)

ρ_g – Gas Density (kg/m³)

LFL – Lower Flammable Limit (Volume fraction)

U_w = Ventilation Velocity (m/sec)

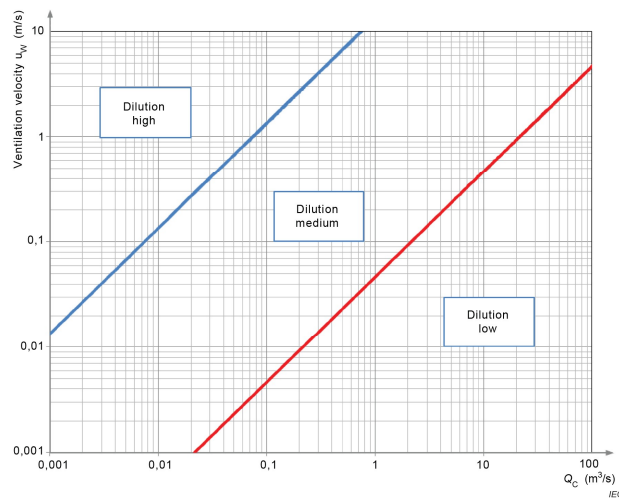

Figure C.1 – Chart for assessing the degree of dilution

Availability of Ventilation

- Good: ventilation is present continuously
- Fair: ventilation is expected to be present during normal operation. Discontinuities are permitted provided they occur infrequently and for short periods
- Poor: ventilation that does not meet the standard of fair or good, but discontinuities are not expected to occur for long periods

Table D.1 – Zones for grade of release and effectiveness of ventilation

Grade of release	Effectiveness of Ventilation						
	High Dilution			Medium Dilution			Low Dilution
	Availability of ventilation						
	Good	Fair	Poor	Good	Fair	Poor	Good, fair or poor
Continuous	Non-hazardous (Zone 0 NE)	Zone 2 (Zone 0 NE)	Zone 1 (Zone 0 NE)	Zone 0	Zone 0 + Zone 2	Zone 0 + Zone 1	Zone 0
Primary	Non-hazardous (Zone 1 NE)	Zone 2 (Zone 1 NE)	Zone 2 (Zone 1 NE)	Zone 1	Zone 1 + Zone 2	Zone 1 + Zone 2	Zone 1 or zone 0
Secondary	Non-hazardous (Zone 2 NE)	Non-hazardous (Zone 2 NE)	Zone 2	Zone 2	Zone 2	Zone 2	Zone 1 and even Zone 0

PCIC energy

52

Types of Ventilation

- Open Air
 - Wind
- Building Ventilation
 - Natural ventilation
 - Artificial Ventilation

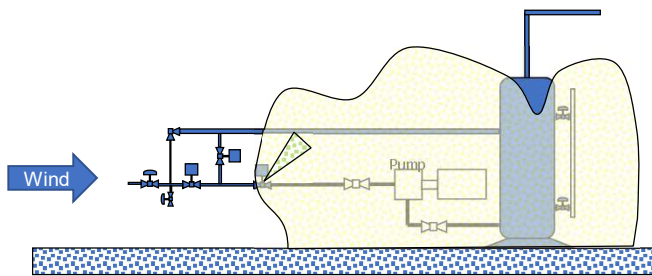
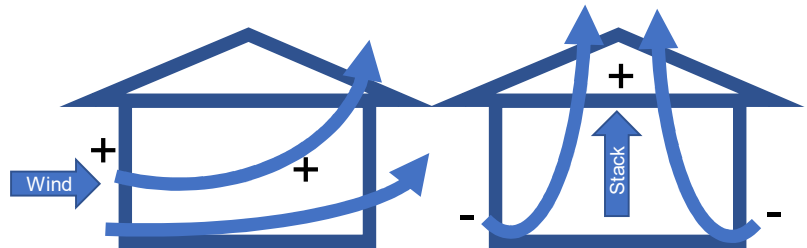

PCIC energy

Open Air

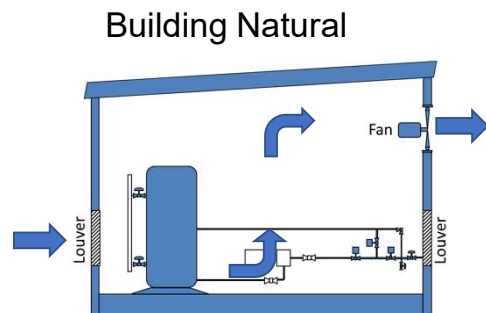

Building Natural

Building Artificial

53

Degree of Dilution: Open Air

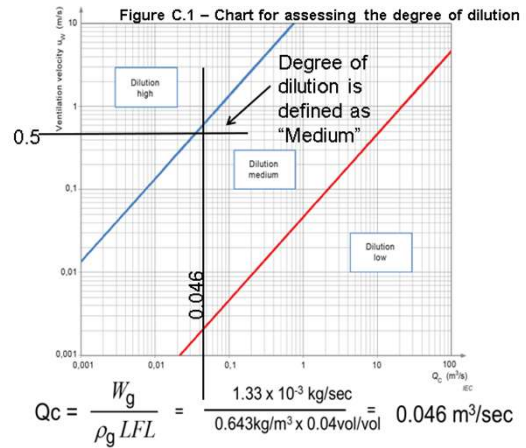
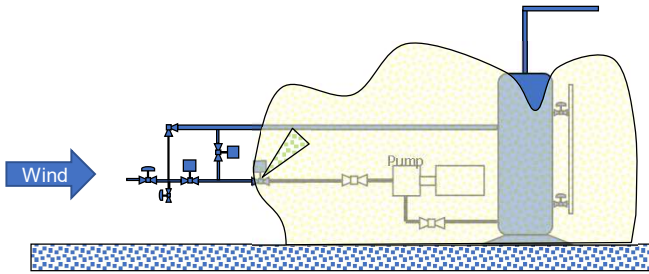

Table C.1 – Indicative outdoor ventilation velocities (u_w)

Type of Release	Unobstructed areas			Obstructed areas		
	≤ 2 m	> 2 m up to 5 m	> 5 m	≤ 2 m	> 2 m up to 5 m	> 5 m
Lighter than air gas/vapour releases	0,5 m/s	1 m/s	2 m/s	0,5 m/s	0,5 m/s	1 m/s
Heavier than air and neutrally bouyant gas/vapour releases	0,3 m/s	0,6 m/s	1 m/s	0,15 m/s	0,3 m/s	1 m/s
liquid pool evaporation rate at any elevation	> 0,25 m/s			> 0,1 m/s		

Availability – Open Air

- Lighter than air release (relative density < 0.8)
 - Availability: Good
- Heavier than air release (relative density ≥ 1.2)
 - Availability: Fair

Table D.1 – Zones for grade of release and effectiveness of ventilation

Grade of release	Effectiveness of Ventilation						
	High Dilution			Medium Dilution	Low Dilution		
	Good	Fair	Poor	Good	Fair	Poor	Good, fair or poor
Continuous	Non-hazardous (Zone 0 NE)	Zone 2 (Zone 0 NE)	Zone 1 (Zone 0 NE)	Zone 0	Zone 0 + Zone 2	Zone 0 + Zone 1	Zone 0
Primary	Non-hazardous (Zone 1 NE)	Zone 2 (Zone 1 NE)	Zone 2 (Zone 1 NE)	Zone 1	Zone 1 + Zone 2	Zone 1 + Zone 2	Zone 1 or zone 0
Secondary	Non-hazardous (Zone 2 NE)	Non-hazardous (Zone 2 NE)	Zone 2	Zone 2	Zone 2	Zone 2	Zone 1 and even Zone 0

Dilution: Enclosed Spaces

- Determined by volumetric flow of the ventilation system divided by the cross-sectional area perpendicular to the flow
- Background concentration calculation required to ensure an adequate air exchange rate to prevent persistence of a flammable atmosphere

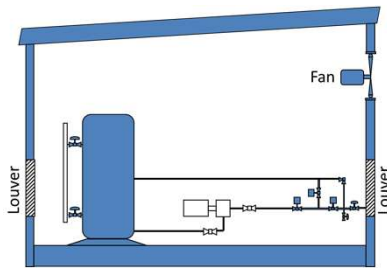

PCIC energy

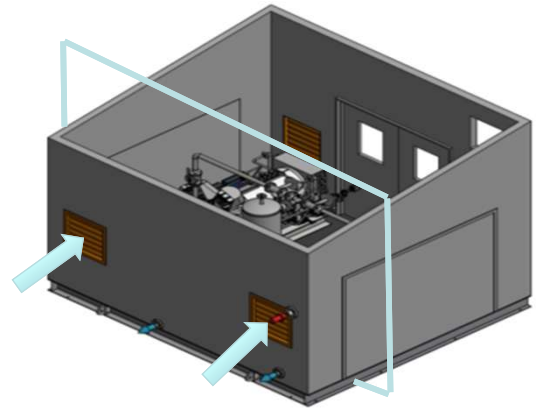

56

Background Concentration

X_b – Background concentration (vol/vol)

$$X_b = \frac{f \times Q_g}{Q_g + Q_1} = \frac{f \times Q_g}{Q_2} \text{ (vol/vol)}$$

$$X_b < X_{crit}$$

$$X_{crit} = 25\% \text{ of the LFL}$$

If the background concentration exceeds 25 % of the LFL, the degree of dilution should be defined as being “Low”

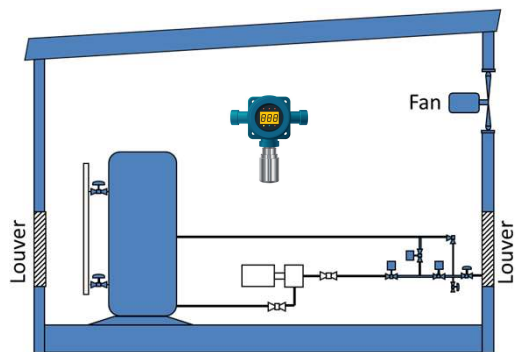

PCIC energy

57

Degree of Dilution

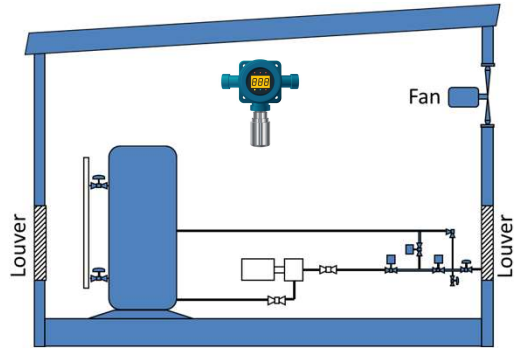

$X_b < 25\%$ LFL 0.006
 Medium dilution is achieved!

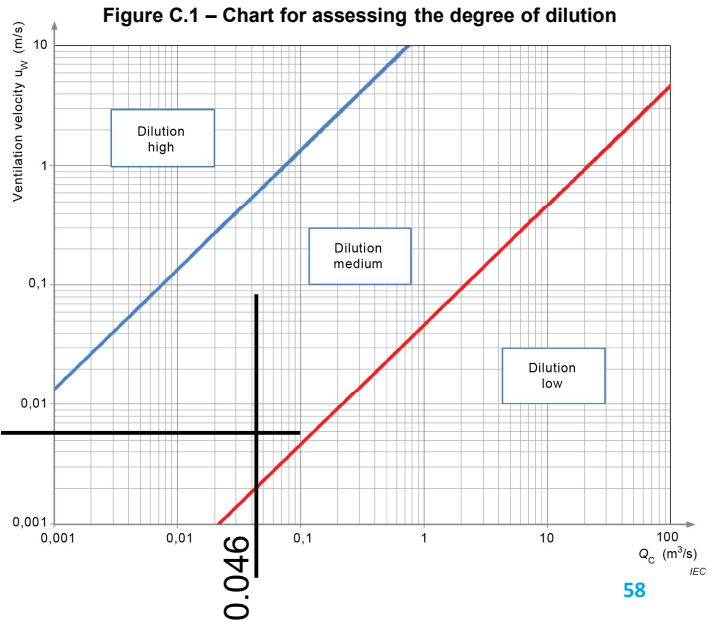

Zone Classification

Table D.1 – Zones for grade of release and effectiveness of ventilation

Grade of release	Effectiveness of Ventilation						
	High Dilution			Medium Dilution		Low Dilution	Good, fair or poor
	Good	Fair	Poor	Good	Fair	Poor	
Availability of ventilation							
	Good	Fair	Poor	Good	Fair	Poor	
Continuous	Non-hazardous (Zone 0 NE)	Zone 2 (Zone 0 NE)	Zone 1 (Zone 0 NE)	Zone 0	Zone 0 + Zone 2	Zone 0 + Zone 1	Zone 0
Primary	Non-hazardous (Zone 1 NE)	Zone 2 (Zone 1 NE)	Zone 2 (Zone 1 NE)	Zone 1	Zone 1 + Zone 2	Zone 1 + Zone 2	Zone 1 or zone 0
Secondary	Non-hazardous (Zone 2 NE)	Non-hazardous (Zone 2 NE)	Zone 2	Zone 2	Zone 2	Zone 2	Zone 1 and even Zone 0

Natural Ventilation

60

- Requires assessment of:
 - Wind induced ventilation
 - Buoyancy (stack effect) induced ventilation
 - Combination of wind induced. and buoyancy induced ventilation

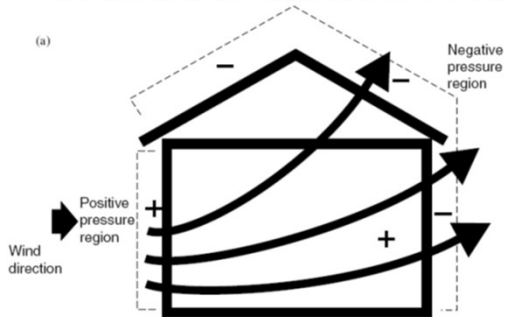

Wind Driven Flow

PCIC energy

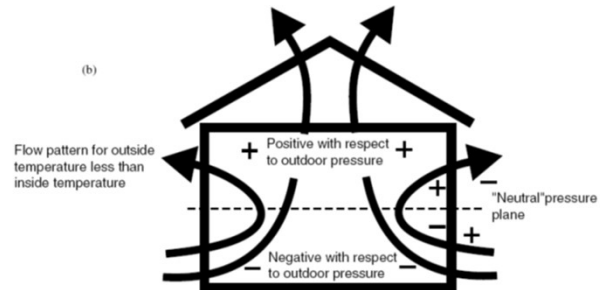

Stack Driven Flow

60

Natural Ventilated Design Example

61

Indoor Ambient = 30°C
Outdoor Ambient = 28°C

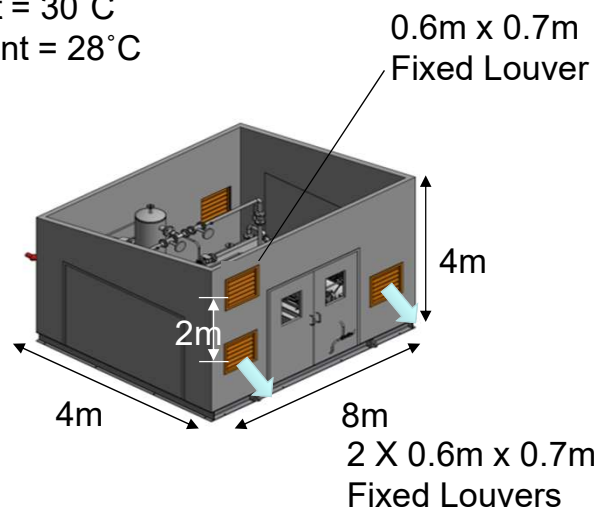
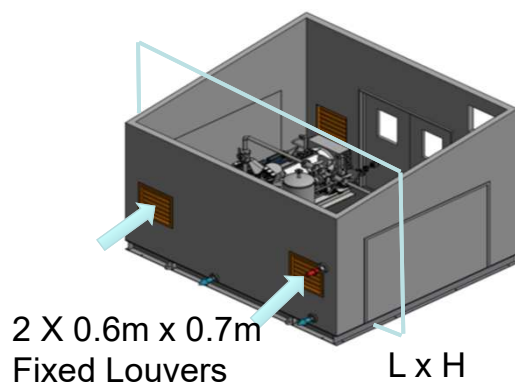

PCIC energy

61

Extent of a Zone

- The distance in any direction from the source of release to where a gas/air mixture will be diluted by air to a concentration below the lower flammable limit

LFL – Lower Flammable Limit
UFL – Upper Flammable Limit

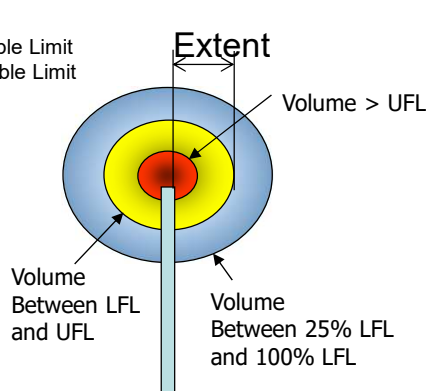

Atmospheric Vent

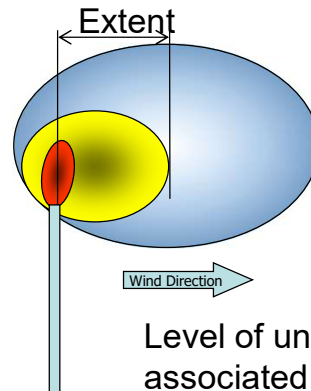

Atmospheric Vent

Level of uncertainty associated with release

Factors that influence Extent:

Density relative to air

- Lighter than air releases will accumulate in the upper regions of enclosed spaces
- Heavier than air release may flow into areas below ground level

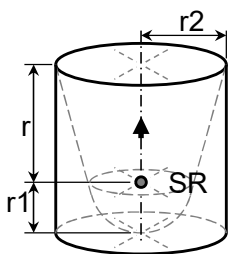

Lighter than Air

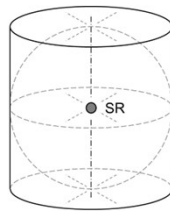

Neutral Density

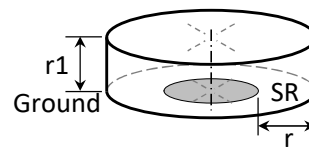

Heavier than Air

Topography:

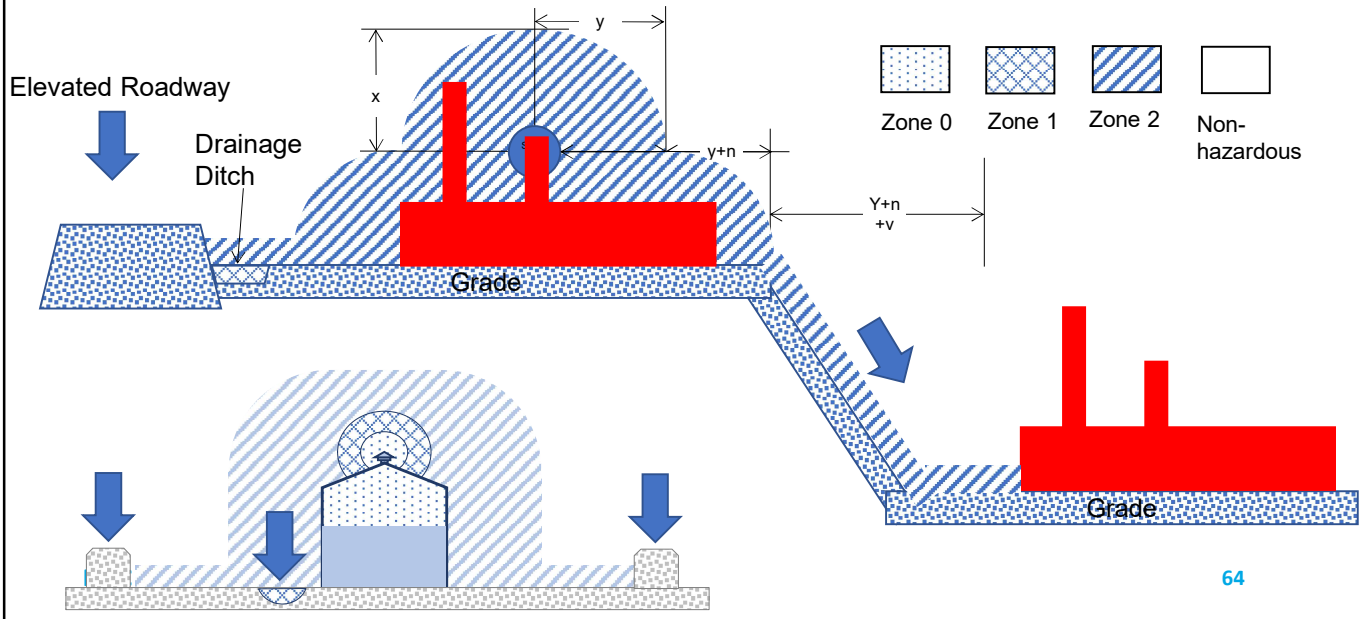

Pressurization and Vapour-tight Barriers

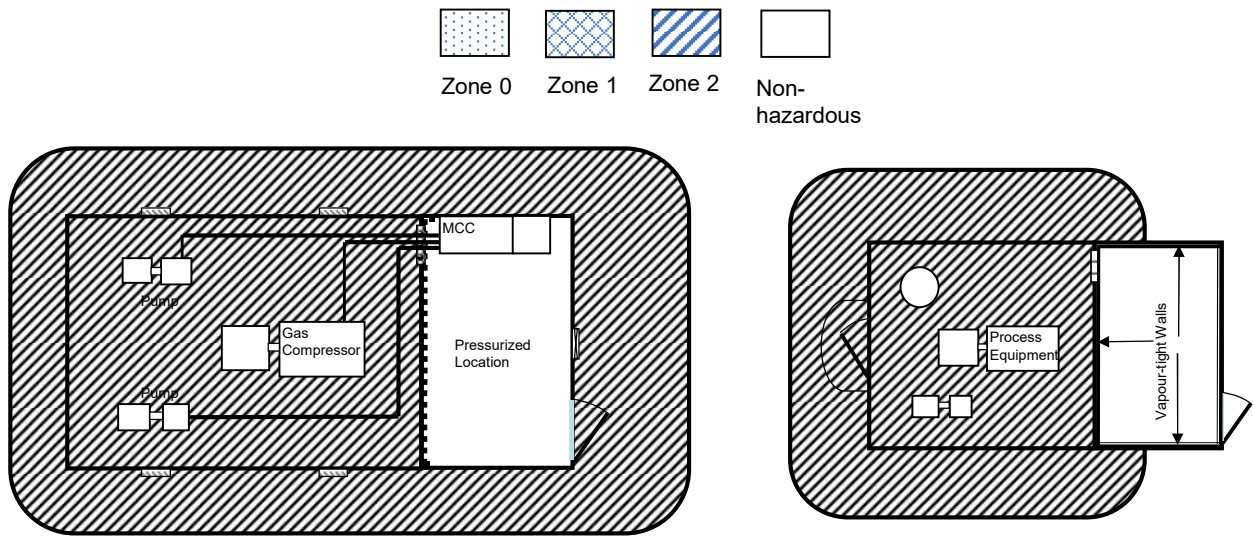

Estimating the Extent

Jet release

- High pressure choked gas releases

Diffusive release

- Low pressure subsonic gas releases

Heavy gas release

- Heavier than air vapour release

Not applicable to indoor extent applications

PCIC energy

Figure D.1 – Chart for estimating hazardous area distances

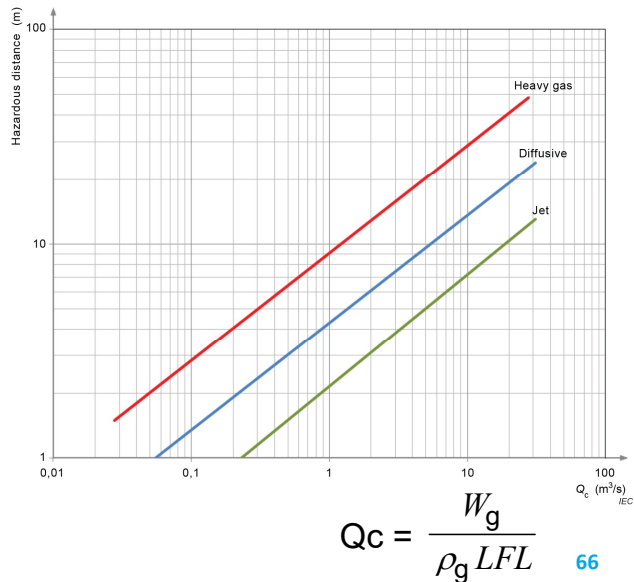

Extent Example

Stream: **Propane**
 Group **IIA**
 AIT: **445 ° C**
 Vapour Density:**1.56**

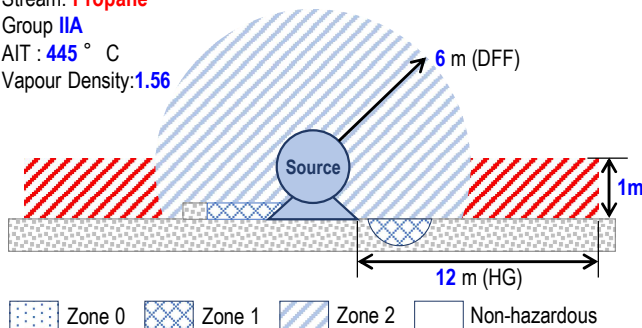

PCIC energy

Figure D.1 – Chart for estimating hazardous area distances

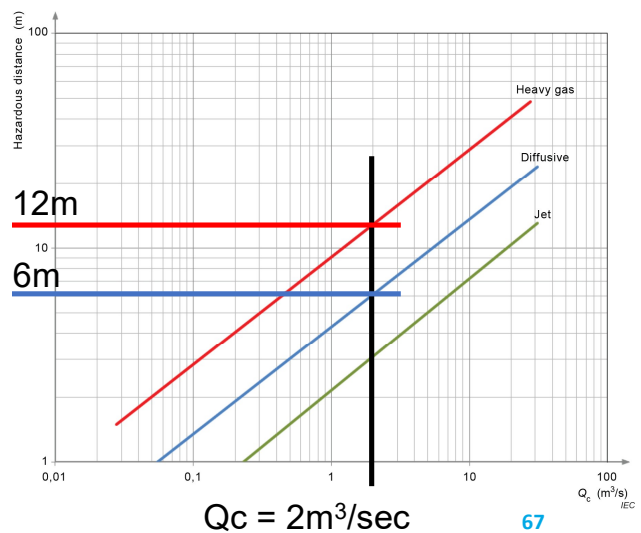

Zone of Negligible Extent (NE)

- Increased air movement reduces the classification extent
- May permit the area surrounding the release to be designated “non-hazardous”
- Subject to an ignition risk assessment
 - Implies that should an explosion take place, it will have negligible consequences
- Gas distributed at > 1000 kPa requires a specific risk assessment
- Shall not be applied to gas distributed at > 2000 kPA

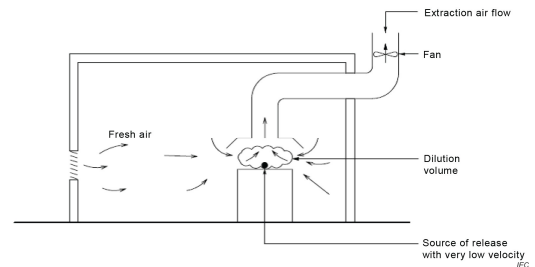
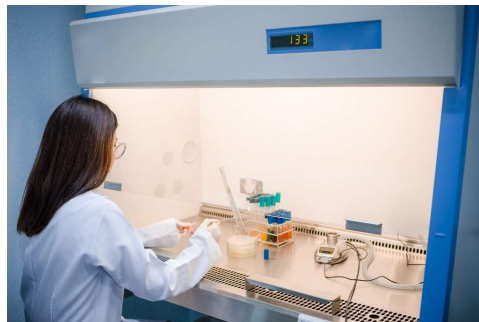

Zone of Negligible Extent

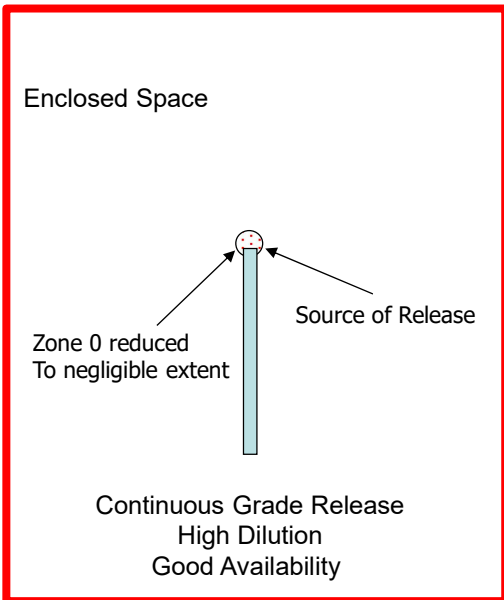

Table D.1 – Zones for grade of release and effectiveness of ventilation

Grade of release	Effectiveness of Ventilation						
	High Dilution			Medium Dilution			Low Dilution
	Availability of ventilation						
	Good	Fair	Poor	Good	Fair	Poor	Good, fair or poor
Continuous	Non-hazardous (Zone 0 NE)	Zone 2 (Zone 0 NE)	Zone 1 (Zone 0 NE)	Zone 0	Zone 0 + Zone 2	Zone 0 + Zone 1	Zone 0
Primary	Non-hazardous (Zone 1 NE)	Zone 2 (Zone 1 NE)	Zone 2 (Zone 1 NE)	Zone 1	Zone 1 + Zone 2	Zone 1 + Zone 2	Zone 1 or zone 0
Secondary	Non-hazardous (Zone 2 NE)	Non-hazardous (Zone 2 NE)	Zone 2	Zone 2	Zone 2	Zone 2	Zone 1 and even Zone 0

Documentation

71

- Plan drawings and cross section drawings
- Hazardous Area Classification Design Basis Document (HAC DBD)

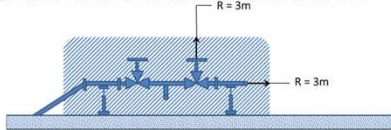
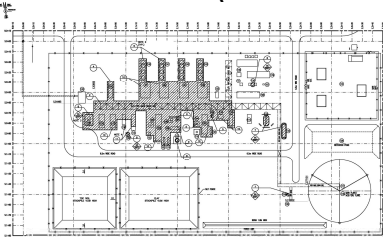

2 Manifold handling HP (ANSI 600 Piping Class) Natural Gas

PCiC energy

 Hazardous Area Classification Design Basis Document			
Generic Facility			
Rev 0	2023.08.01	Doc# HACDBD1	Table of Contents
1.0	EXECUTIVE SUMMARY		
1.1	CONDITIONS OF USE		
2.0	DESIGN BASIS		
2.1	REGULATORY REQUIREMENTS		
2.2	REFERENCES		
2.3	PROCESS DESCRIPTION		
2.4	DESIGN APPROACH		
2.5	FLAMMABLE MATERIAL PROPERTIES		
2.5.1	GROUP CLASSIFICATION		
2.5.2	AUTO-IGNITION TEMPERATURE		
2.6	SOURCE OF RELEASE IDENTIFICATION AND ASSESSMENT		
2.7	VENTILATION ASSESSMENT		
2.8	ZONE CLASSIFICATION ASSESSMENT		
2.9	ZONE EXTENT ASSESSMENT		
3.0	APPLICATION TO THE FACILITY		
3.1	UNIT 1 PLANT LAYOUT		
3.1.1	AREA 1 VENTILATION REQUIREMENTS		
3.1.2	AREA 2 OPERATIONAL RESTRICTIONS		
3.2	UNIT 2 PLANT LAYOUT		
3.2.1	AREA 1		
3.2.2	AREA 2		
ANNEX A – REFERENCE INFORMATION			
PROCESS FLOW DIAGRAMS			
FACILITY PLOT PLAN			
VENTILATION DESIGN DATA			
ANNEX B – HAZARDOUS AREA CLASSIFICATION DATA SHEETS			
PART I: FLAMMABLE SUBSTANCE LIST AND CHARACTERISTICS			
PART II: LIST OF SOURCES OF RELEASE			
ANNEX C – HAZARDOUS AREA CLASSIFICATION DRAWINGS			
PLOT PLAN			
CROSS-SECTIONS			
TYPICAL DETAILS			

HAC Drawings

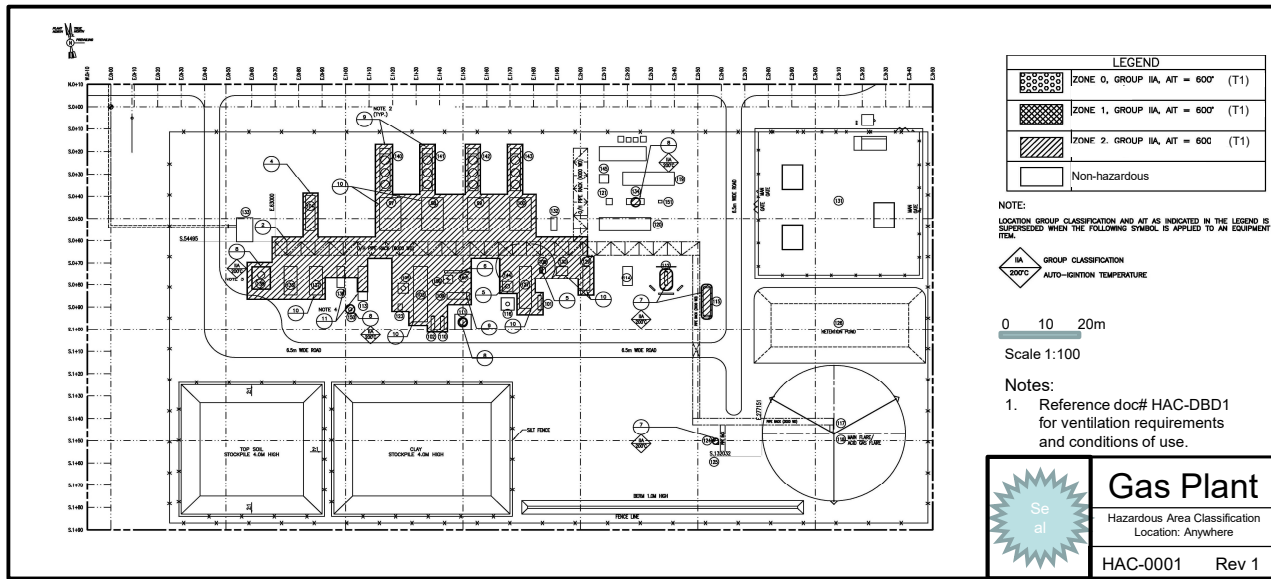

PCIC energy

72

Section Drawings and Details

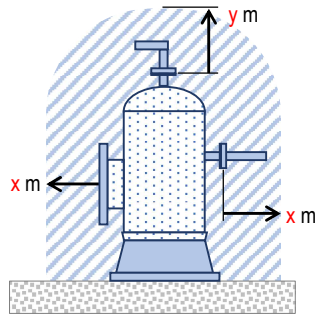

Zone 0 Zone 1 Zone 2 Non-hazardous

Process Vessel

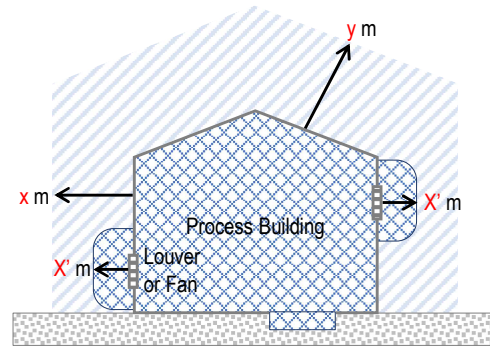

Zone 0 Zone 1 Zone 2 Non-hazardous

Inadequately Ventilated Process Building

PCIC energy

73

IEC 60079-10-1 Flammable Materials Worksheet

Hazardous area classification data sheet - Part I: Flammable substance list and characteristics

FM Name EngWorks HAC Course Dehy Facility															
1	2	3	4	5	6	7	8	9	10	11	12	13	14	15	
Flammable substance										Volatility *		LFL/ UFL		Ex Characteristics	
Name	Composition	Molar mass (kg/kmol)	Relative density gas/ air	Polytropic index of Adiabatic Expansion (γ)	Flash point (° C)	Ignition temp. (° C)	Boiling point (° C)	Vapour pressure at 20° C (kPa)	vol (%)	(kg/m3)	Equipment group ^b	Temp. class	Any other relevant information or remark		
1	Gas Mixture	0.50% <i>n</i> -Octane, 0.50% <i>n</i> -Heptane, 0.50% <i>n</i> -Hexane, 3.00% <i>n</i> -Pentane, 1.50% <i>n</i> -Butane, 2.50% <i>n</i> -Propane, 6.00% <i>n</i> -Ethane, 60.00% <i>n</i> -Methane, 13.50% <i>n</i> -H ₂ S, 3.50% <i>n</i> -CO ₂ , 6.50% <i>n</i> -H ₂ O, 2.00% <i>n</i> -N ₂	23.3	0.81	1.232	-171.6	515	-114.6	3263.588	3.5	0.034	IIA	T1	AIT estimated using mole weight average	
										17.57	0.17				
2	Water Mixture	0.50% <i>n</i> -Decane, 0.50% <i>n</i> -Nonane, 0.50% <i>n</i> -Octane, 0.50% <i>n</i> -Heptane, 95.00% <i>n</i> -Pentane	72.15	2.49	1.122	-40	243	90.6	1.698	1.1	0.033	IIA	T2C	AIT estimated using 3% Rule	
										8.7	0.261				

^a Normally the value of vapour pressure is given, but in the absence of that, boiling point can be used;
^b Value in second line is user defined.

IEC 60079-10-1 Source of Release Worksheet

Hazardous Area Classification Data Sheet - Part II List of Sources of Release

Plant: Dehy Plant Area: All																Reference Drawing: W40178-01	
1	2	3	4	5	6	7	8	9	10	11		12		13	14	15	16
No. ^a	Description	Source of Release Location	Grade of Release ^a	Rate of Release (kg/s)	Release Characteristic (m ³ /s)	Reference ^b	Flammable Material		State ^c	Type ^d	Ventilation		Hazardous Area		Reference ^e	Any other relevant information and remarks	
							Operating Temperature and Pressure				Degree of Dilution ^f	Avail-ability	Zone Type 0-1-2	Zone Extent (m)			
							(° C)	(kPa)				Vertical	Horizontal				
1	Valves, flanges, instrumentation, open ended devices	Inlet Sep/Water KO Building	S	2.67E-04	9.88E-03	(1) Gas Mixture	55	630	G	N	Medium	Fair	2	Extent of Building + 1.0m		IEC 60079-10-1	Building Naturally Ventilated at 4 ACPH
2	Analyzer tubing, analyzer vents, sales gas valve	Meter Building	S P (Analyzer Vent)			(1) Gas Mixture			G	A	Medium	Fair	1	Extent of Building		API RP 505 Figure 14, 26 Section 6.8.2	Building ventilated at 6 ACPH. Building incorporates gas detection configured to blast fans at 20% LEL and ventilate building at 12 ACPH
													2	1.5m surrounding Building		Building forced ventilated at 3 ACPH	
3	Valves, flanges, instrumentation, open ended devices	Dehy Building	S	4.00E-04	1.00E-02	(1) Gas Mixture (2) Water Mixture	55	610	G	A	Medium	Fair	2	Extent of Building + 1.0m		IEC 60079-10-1	Building forced ventilated at 3 ACPH
4	Compressor and pump seals, sales gas valve	Regen Gas Compressor Building	S	3.00E-03	2.00E-02	(1) Gas Mixture	120	4300	G	A	Medium	Fair	1	Extent of Process Area in Building		IEC 60079-10-1	Building forced ventilated at 3 ACPH. Vapourtight Barrier between process and electrical room
5	Flanges	Regen Gas Cooler	S			(1) Gas Mixture	120	4300	G	N	Medium	Good	2	Perimeter of Cooler		API RP 505 6.5.9.1.1 10.15.1.1	
													Non-Hazardous		Heater is Non-hazardous due to open flame		
6	Flanges	Regen Gas Heater	S			(1) Gas Mixture	120	4300	G	N	Medium	Good	Non-Hazardous		API RP 505 6.5.9.2	Heater is Non-hazardous due to open flame	
7	Valves, flanges, instrumentation, screwed connections	Heater Fuel Gas Skid	S			Low Pressure Fuel Gas			G	N	Medium	Good	2	1	1	API RP 505 10.15.2.1	Fuel gas skid handles very low pressure fuel gas for the fired heater and is considered very low risk
8	Tank Vent	Produced Water Storage Tanks	P - Vent S			(2) Water Mixture	40	Amb	G/L	N	Medium	Good	2	3	3	API RP 505 10.8.1.1.3 Figure 50	Zone 1 surrounds tank vent
9	Flare KO Pump Seal, Hatch opening	Flare KO Drum	S			Slop Oil	40	Amb	G/L	N	Medium	Good	2	3	3	API RP 505 Figure 100	
10	None	Flare Stack				All	40	Amb	G/L	N	Medium	Good	Non-Hazardous		API RP 505 6.5.9.2	Flare is Non-hazardous due to open flame	
													1	1.5 from Launch Receiver		API RP 505 Figure 49	
11	Pig launching and receiver operations	Pig Launcher	P			(1) Gas Mixture	20	Amb	G	N	Medium	Fair	2	1.5-3m from Launch Receiver			
													Non-Hazardous				

Change Management IEC 60079-10-1

- *“Once a plant has been classified and all necessary records made, it is important that no modification to equipment or operating procedures is made without discussion with those responsible for the area classification.”*
- *Unauthorised action may invalidate the area classification.*



Create



Review



Approve

Summary

- Risk assessment process that covers
 - Properties of flammable and combustible materials
 - Probability of release
 - Sources of release
 - Normal vs. abnormal operations
 - Effects of environmental parameters
 - Ventilation
- Based on the likelihood of a flammable mixture being present in normal operation
- Must be carried out before equipment is specified
- Supporting documentation is extremely important!



Est-ce que je peux poser une question ?

Can I ask a Question?